

**MANUAL DE MONTAGEM  
ASSEMBLY INSTRUCTIONS  
INSTRUCCIONES DE MONTAJE**

COD BR: BC 82



# Sumário Summary Resumen

Introdução Introduction Introducción	.....	3
Antes de começar Before starting Antes de comenzar	.....	4
Evite acidentes Avoid accidents Evitar accidentes	.....	4
Dimensões e ferramentas Dimensions and tools Dimensiones y herramientas	.....	5
Identificação das peças Identifying parts Identificación de las piezas	.....	6
Acessórios incluídos na caixa Hardware included in box Accesorios incluidos en la caja	.....	7
Montagem do móvel Furniture assembly Montaje del mueble	.....	8

## Introdução Introduction Introducción

Leia atentamente este manual e siga os passos indicados para que o produto não perca a garantia e também para uma perfeita montagem.

Read this manual and follow the steps in order to keep the guarantee and also for the perfect fit.

Lea este manual y siga los pasos para que el producto no pierda la garantía y también para el ajuste perfecto.

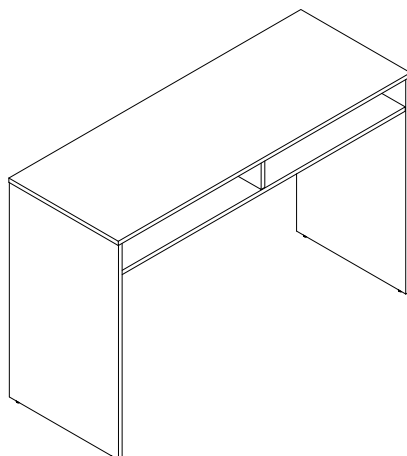

## Antes de começar Before starting Antes de comenzar

Antes de começar a montagem prepare o ambiente, deixando-o completamente limpo e com bom espaço para iniciar o trabalho.

Prepare the room before starting the assembly, leaving it completely clean and the area in good condition to start the work.

Antes de comenzar el montaje preparar el ambiente, dejándolo completamente limpio y con bueno espacio para comenzar el trabajo.

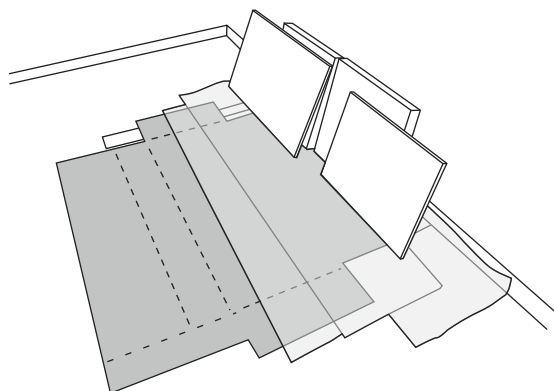

Utilize o papelão da própria embalagem para separar e apoiar as peças retiradas das caixas.

Use the cardboard of the packaging to separate and support the parts removed from the boxes.

Utilice el cartón de la embalaje para separar y apoyar las piezas desmontadas de las cajas.



Forre a área de montagem com um cobertor ou tapete. Assim, você evita avarias nas peças durante o processo de montagem.

Cover the assembly area with a blanket or carpet to avoid damaging the parts during the assembly process.

Cubrir la zona de ensamble con una manta o alfombra. De este modo, se evitan daños en las piezas durante el proceso de montaje.



## Evite acidentes Avoid accidents Prevenir accidentes

Solicitamos observar atentamente as orientações de montagem como: fixação do produto na parede, colocação de cola em locais específicos necessários, o peso suportado pelo produto, etc...

You are requested to carefully observe the assembly instructions regarding: fixing of products to the wall, adding glue where indicated, product weight limit, etc.

Pedimos que lea atentamente las instrucciones, principalmente las informaciones de fijación del producto en la pared, colocación de pegamento en local específico y necesario, el peso soportado por el producto etc...

Não escale ou se apoie no móvel.

Do not climb or lean on the furniture.

No se suba ni se apoye en el mueble.

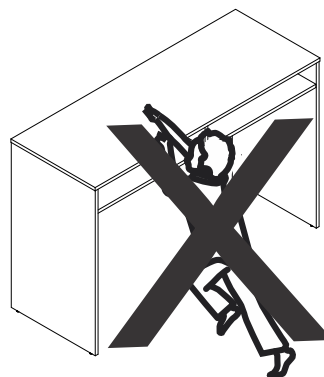

Dimensões e ferramentas  
Dimensions and tools  
Dimensiones y herramientas

Dimensões:

L: 1200 A: 785 P: 450 mm

Dimensions:

W: 47.24 H: 30.90 D: 17.71 inches

Dimensiones:

L: 1200 A: 785 P: 450 mm

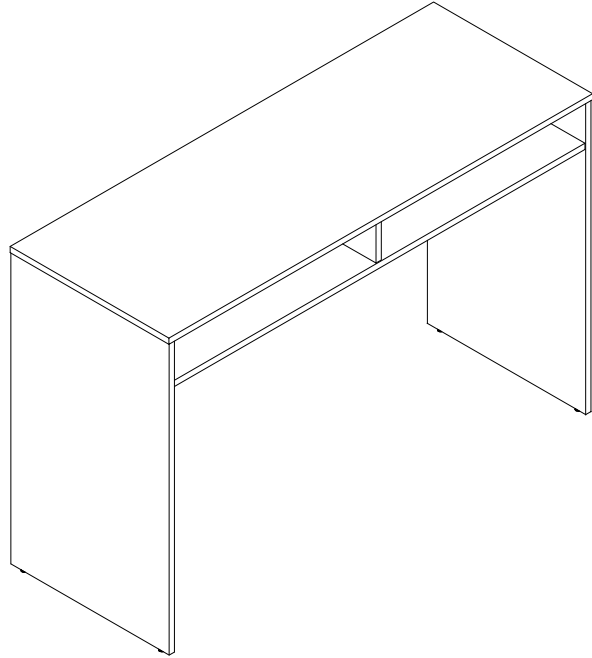

Limpeza  
Cleaning  
Limpieza

Pano levemente umedecido com água, seguido de pano seco, não utilizar produtos químico ou abrasivos.  
You can clean the product with slightly dampened cloth followed by a dry cloth. Do not use chemicals or abrasives.  
Solamente utilizar un paño húmedo y después un paño seco, no utilice productos químicos o abrasivos.

Todas as peças do móvel foram marcadas com um número. Antes de começar a montagem, identifique as peças numeradas em relação às instruções de montagem. Uma vez concluída a montagem, os números podem ser facilmente removidos com um pano ligeiramente embebido em álcool. Use álcool apenas para remover números das peças.

All the furniture parts have been marked with a number. Before you start assembling, please identify the numbered parts in relation to the assembly instructions. Once assembly is completed, the numbers can be easily removed with a cloth slightly damped in alcohol. Use alcohol only to remove part numbers.

Todos las piezas del mueble fueron marcadas con un número. Antes de empezar el montaje, identifique las piezas numeradas en relación con las instrucciones de montaje. Una vez que se completa el armado, los números se pueden quitar fácilmente con un paño ligeramente empapado en alcohol. Use alcohol solo para eliminar números de las piezas.

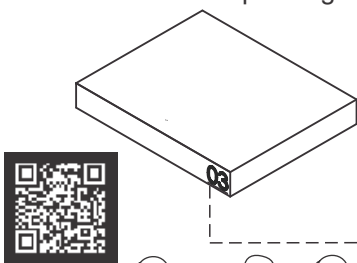

**UTILIZE ALCOOL APENAS PARA REMOVER O NUMERO DAS PEÇAS**  
**USE ALCOHOL ONLY TO REMOVE PART NUMBERS**  
**UTILICE ALCOHOL SOLAMENTE PARA ELIMINAR EL NUMERO DE LAS PIEZAS**

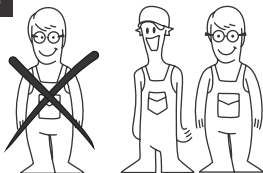

Para facilitar a montagem, utilize uma parafusadeira elétrica.  
To speed assembly, use an electronic screwdriver.  
Para facilitar el armado, utilice un destornillador eléctrico.

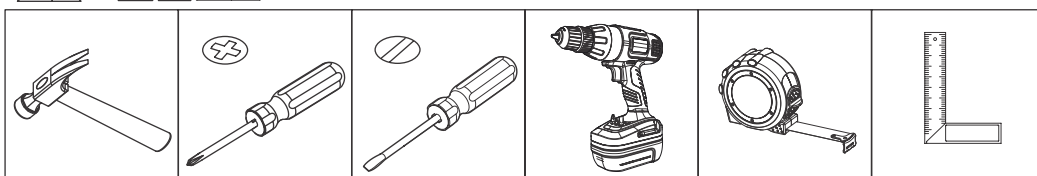

# COD BR: BC 82

PEÇA	DESCRIÇÃO	QUANT.	PART	DESCRIPTION	QTY	PIEZA	DESCRIPCIÓN	CANTIDAD
001	TAMPO	1	001	TOP	1	001	TAPA	1
002	PRATELEIRA	1	002	SHELF	1	002	REPISA	1
003	LATERAL ESQUERDA	1	003	LEFT SIDE	1	003	LATERAL IZQUIERDA	1
004	DIVISÓRIA	1	004	PARTITION	1	004	PARTICIÓN	1
005	TRAVESSA	1	005	TRAY	1	005	TRAVESAÑO	1
006	LATERAL DIREITA	1	006	RIGHT SIDE	1	006	LATERAL DERECHA	1

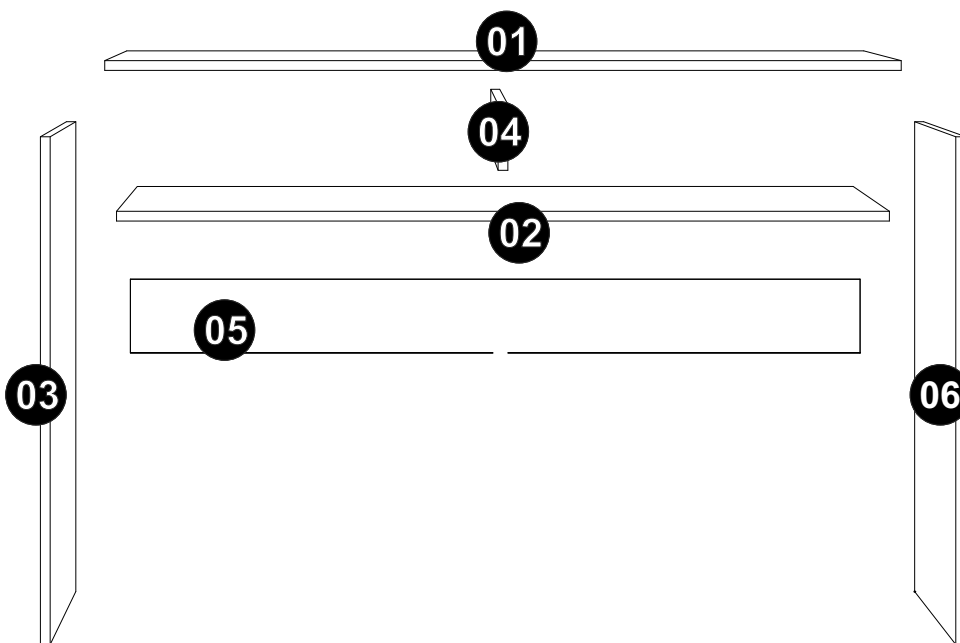

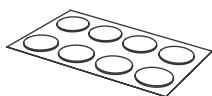

TAPA FUROS x 14  
STICKER x 14  
TAPAS PLÁSTICAS x 14



EF 000168 X 4  
10X10 C/C



EF 000132 x 2  
4X50 CC



EF 000033 x 14  
8x30



GIZ x 1  
CHALK x 1  
TIZA x 1



EF 000216 X 12



EF 000094 X 12



PÉS x 4  
FEET x 4  
PIES x 4

Utilize para medir as ferragens.

Utilice para medir el herraje.

Use for measuring the hardware.

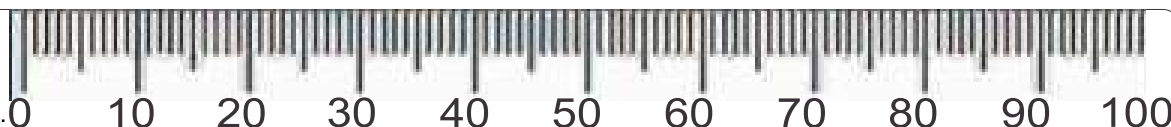

**Garantia (exclusivo para o Brasil/exclusivo de Brasil/exclusive to Brazil):**

A garantia dos produtos fabricados pela BRV Móveis, abrange eventuais defeitos-vícios de fabricação, no prazo estabelecido pelo código de Defesa do Consumidor, em seu artigo 26.II. o qual prevê a garantia de 90 (noventa) dias.

**A** = 19KG - 41.8LB

**B** = 8KG - 17.63LB

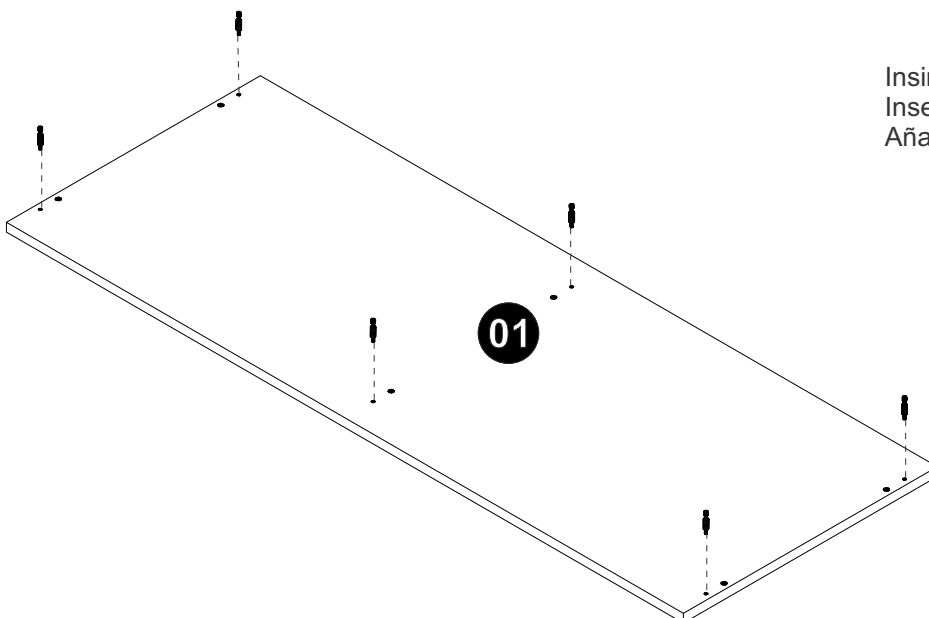
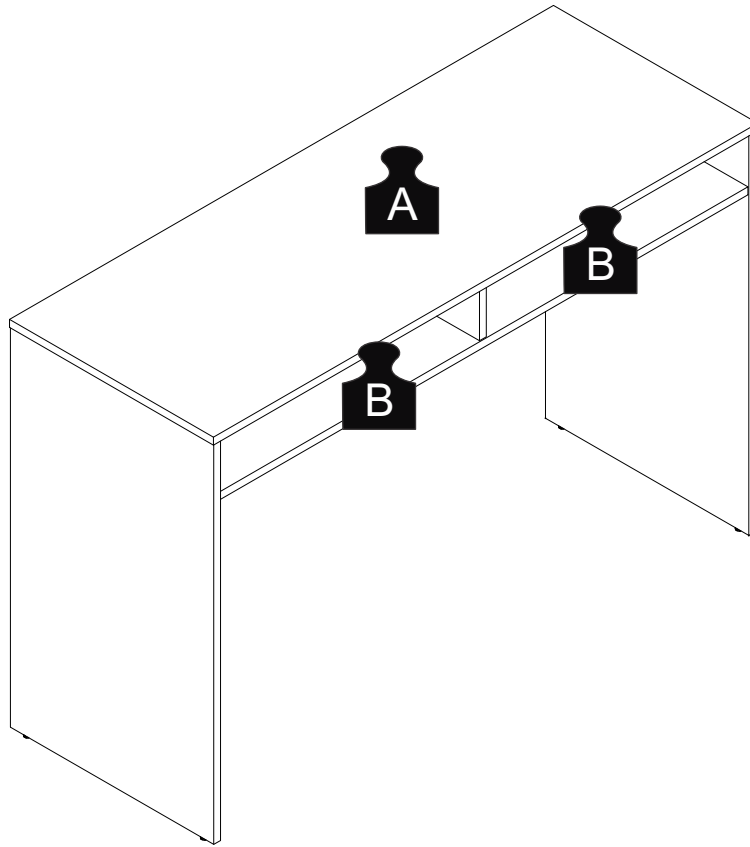

**PASSO 1 / STEP 1 / PASO 1**

Insira a ferragem EF 000094 na peça 01.  
Insert hardware EF 000094 into piece 01.  
Añade el herraje EF 000094 en la pieza 01.

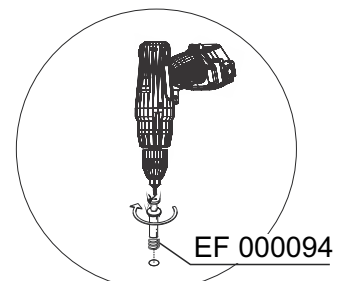



## PASSO 2 / STEP 2 / PASO 2

Insira a ferragem EF 000033 e EF 000094 nas peças 03 e 06.  
Insert hardware EF 000033 and EF 000094 into pieces 03 and 06.  
Añade el herraje EF 000033 y EF 000094 en las piezas 03 y 06.

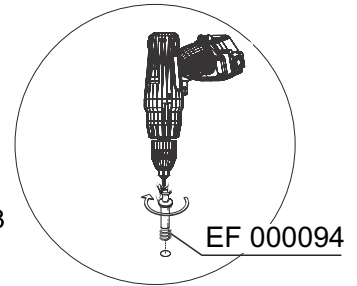
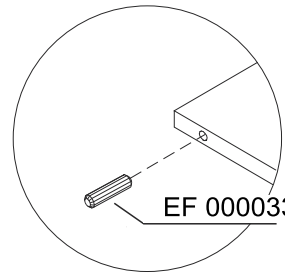
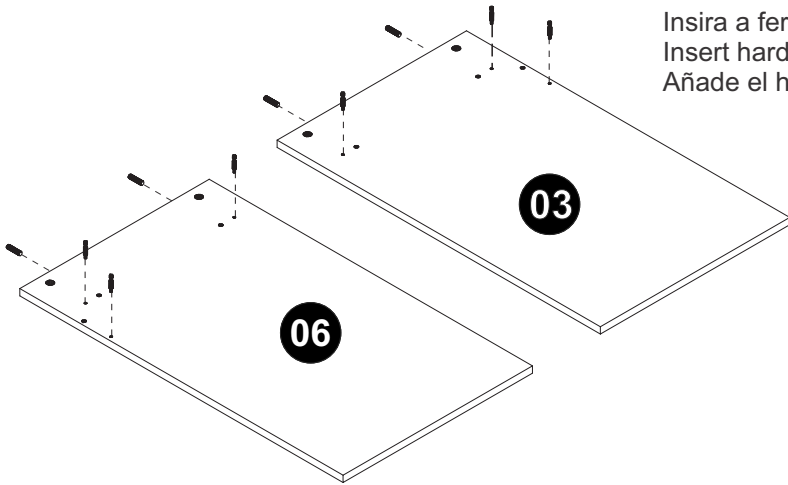

## PASSO 3 / STEP 3 / PASO 3

Insira a ferragem EF 000033 nas peças 02, 04 e 05.  
Insert hardware EF 000033 into pieces 02, 04 and 05.  
Añade el herraje EF 000033 en las piezas 02, 04 y 05.

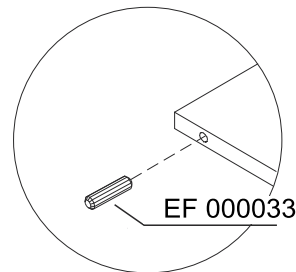
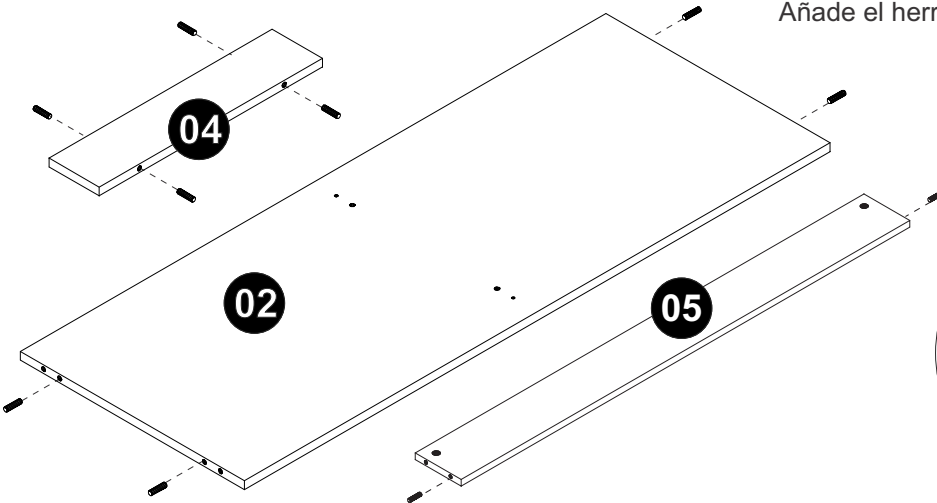

## PASSO 4 / STEP 4 / PASO 4

Use a ferragem EF 000132 para fixar as peças 02 e 04.  
Use hardware EF 000132 to attach pieces 02 and 04.  
Utilice el herraje EF 000132 para fijar las piezas 02 y 04.

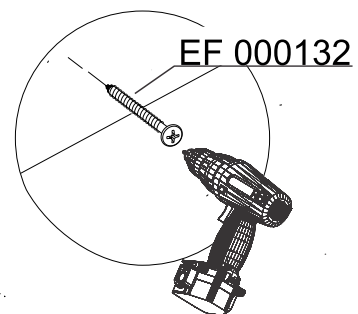
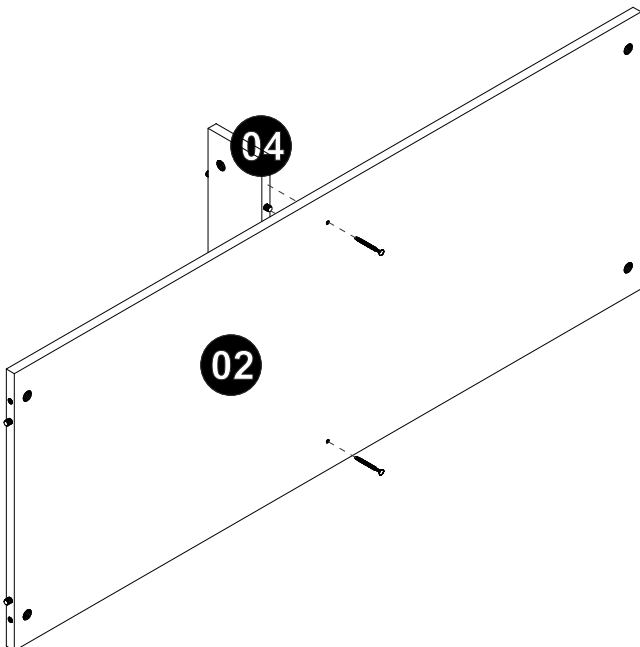

### PASSO 5 / STEP 5 / PASO 5

Conecte as peças 02, 03, 05 e 06, insira a ferragem EF 000216 e gire para apertar.

Connect pieces 02, 03, 05 and 06, insert hardware EF 000216 and turn to tighten.

Junte las piezas 02, 03, 05 Y 06, añada el herraje EF 000216 y gire para apretar.

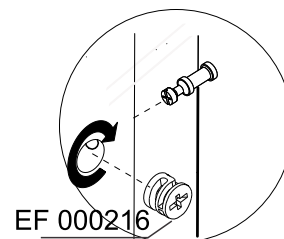
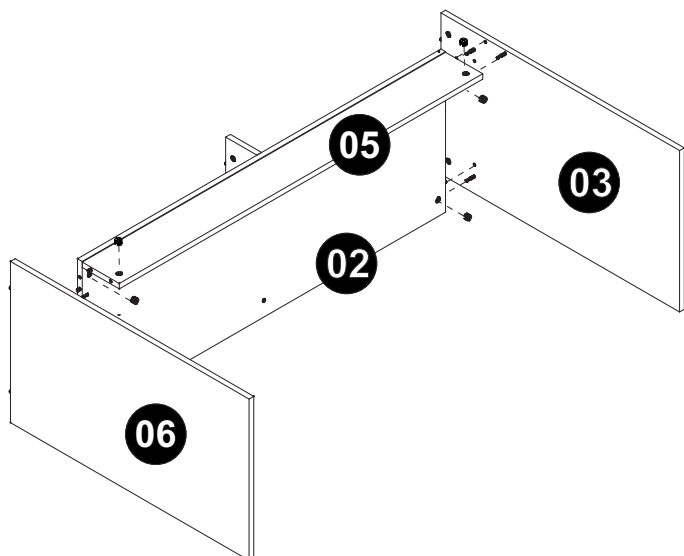

### PASSO 6 / STEP 6 / PASO 6

Conecte a peça 01 e a parte montada no passo anterior, insira a ferragem EF 000216 e gire para apertar.

Connect piece 01 to the part assembled in the previous step, insert hardware EF 000216 and turn to tighten.

Junte la pieza 01 a la parte armada en el passo anterior, añada el herraje EF 000216 y gire para apretar.

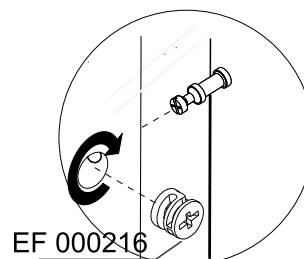
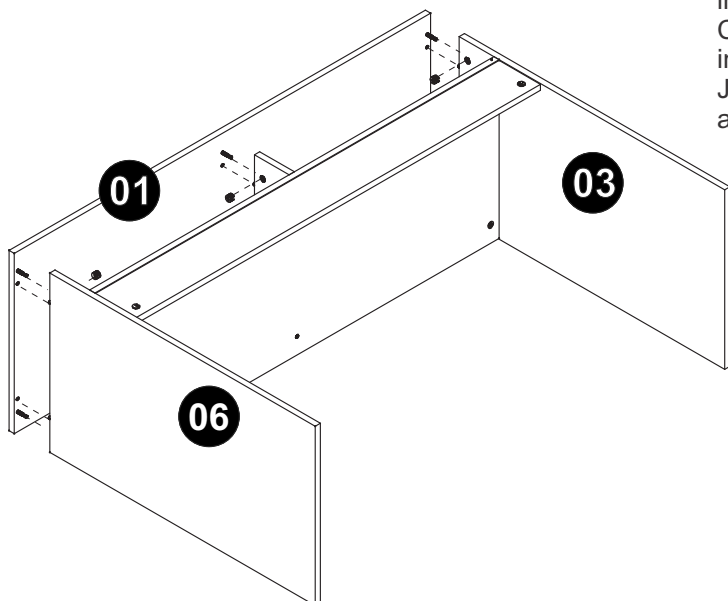

### PASSO 7 / STEP 7 / PASO 7

Fixe os pés utilizando a ferragem EF 000168.

Attach the feet using hardware EF 000168.

Fije los pies utilizando el herraje EF 000168.

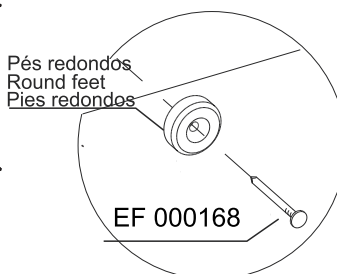
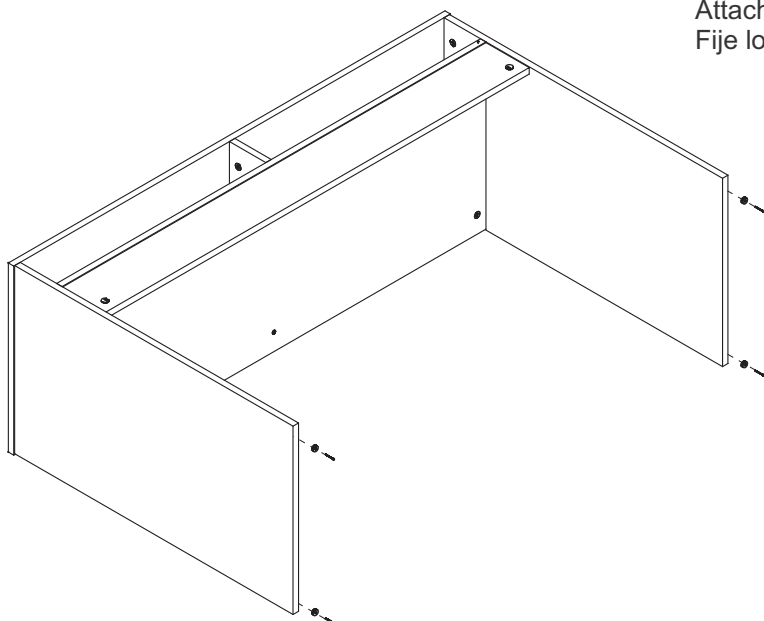

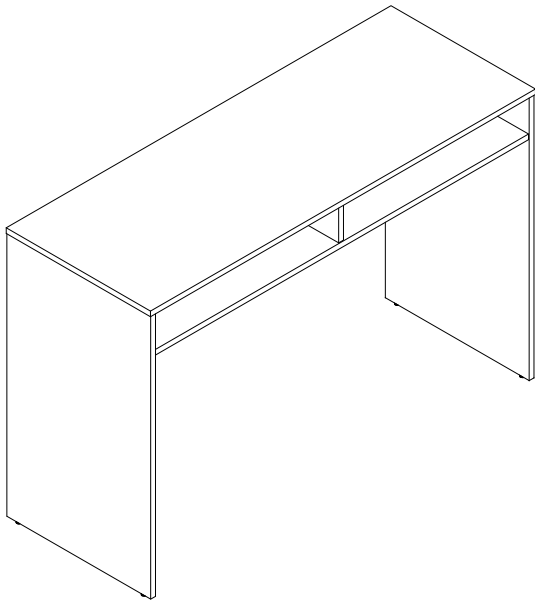

### PASSO 8 / STEP 8 / PASO 8

Utilize o tapa furos para cobrir os parafusos aparentes.  
Use the sticker to cover the apparent screws.  
Utilice los tapa huecos para cubrir los tornillos aparentes.

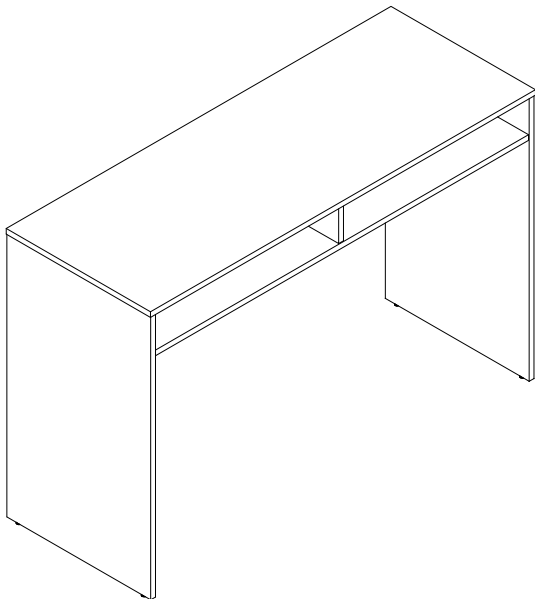
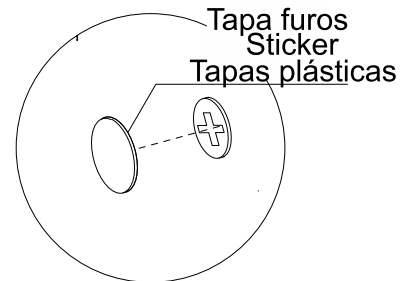

### PASSO 9 / STEP 9 / PASO 9

Use o giz para dar o acabamento final ao produto.  
Use the chalk to give the final finish on the product.  
Utilice la tiza para dar el acabado final al producto.

